

# English Ready

22482VIC Course in Initial EAL  
VU22579 Use strategies to participate in learning

# Learn English



Name \_\_\_\_\_

Teacher \_\_\_\_\_

Class \_\_\_\_\_

Date \_\_\_\_\_

**Design team:** Vicki Hambling, Sue Paull, Frida Dean and Mary Wallace

**Illustrations:** Madelena Scott

**Acknowledgements:** The design team would like to thank the AMEP service providers and practitioners who participated in the trial and gave valuable feedback. The team would also like to acknowledge the use of the EAL Framework which underpins the design of this book.

Copyright of the EAL Framework is reserved to the Crown in the right of the State of Victoria.  
© State of Victoria (Department of Education and Training) 2018.

This English Ready Resource is licensed under a Creative Commons Attribution-NoDerivs 3.0 Australia licence (More information is available [here](#)). You are free to use, copy and distribute to anyone in its original form as long as you attribute Department of Home Affairs as the author and you license any derivative work you make available under the same licence.

© Commonwealth of Australia 2023



With the exception of the Commonwealth Coat of Arms, the department's logo, any material protected by a trade mark and where otherwise noted all material presented in this document is provided under a Creative Commons Attribution 4.0 International (<https://creativecommons.org/licenses/by/4.0/>) licence.

The details of the relevant licence conditions are available on the Creative Commons website (accessible using the links provided) as is the full legal code for the CC BY 4.0 licence (<https://creativecommons.org/licenses/by/4.0/legalcode>).

Use of all or part of this document must include the following attribution:

© Commonwealth of Australia 2023

As far as practicable, material for which the copyright is owned by a third party will be clearly labelled. The department has made all reasonable efforts to ensure that this material has been reproduced in this document with the full consent of the copyright owners.

Copyright requests and enquiries concerning usage not addressed by the CC BY 4.0 licence should be addressed to: [comms@homeaffairs.gov.au](mailto:comms@homeaffairs.gov.au) at the Department of Home Affairs.

The terms of use for the Commonwealth Coat of Arms are available from the [It's an Honour](#) website.

Where a copyright owner, other than the Commonwealth, is identified with respect to this material, please contact that third party copyright owner directly to seek permission.



## Table of contents

1	Instructions.....	2
2	Do you understand? .....	3
3	Meet the students and teachers.....	4
4	What is your name? .....	5
5	Where do you learn English? .....	6
6	Who is your teacher? .....	7
7	I go to class today. ....	8
8	When do you start class? .....	14
9	I am sorry. I am late. ....	16
10	Do you have a pencil?.....	20
11	I want to learn English.....	28
12	Follow instructions.....	38
13	I am sick.....	44

# 1 Instructions



Mime and point to each instruction.

1.



listen

2.



say

3.



copy

4.

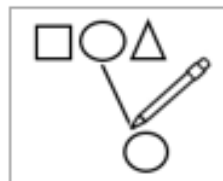

match

5.



colour

6.



circle

7.



trace

8.



tick

9.



point

10.



clap

## 2 Do you understand?



1.

Do you understand?



Yes



No

2.



Do you understand?

Yes, I understand.



No, I don't understand.

Say it again please?



don't = do not

# 3 Meet the students and teachers.



Project the page. Students point to the students and teachers.  
Name the characters. Create sentences. e.g. *Zarni is a student.*  
See teacher Resources for more activities.

## Students



1. Zarni



2. San



3. Jamila

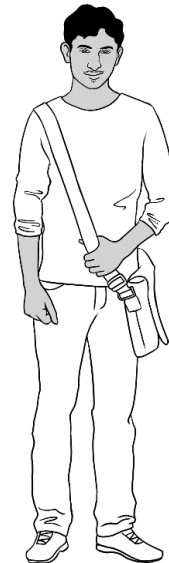

4. Rahim



5. Ming

## Teachers



6. Rosie



7. Wendy



8. Peter

# 4 What is your name?



What is your name?



1.



My name is Ming.

My name is Jamila.



2.



My name is Zarni.

My name is San.



3.

My name is Rahim.

What is your name?



4.



My name is \_\_\_\_\_ .

# 5 Where do you learn English?



Project the page. In Exercise 3, insert the place where **your** classes are held.

1.



I learn at a community centre.

2.



We learn at TAFE.

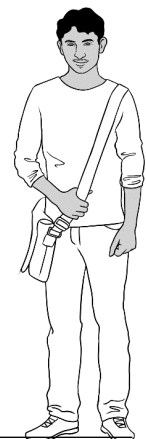

3.



Where do you learn?

I learn at \_\_\_\_\_.



# 6 Who is your teacher?



1.



My teacher is **Wendy**.



2.



My teacher is **Rosie**.



3.



My teacher is **Peter**.



4.



Who is your teacher?

My teacher is \_\_\_\_\_.

# 7 I go to class today.



Project the page.



Colour the boxes above the days when Ming goes to class.

This is Ming's timetable.

Monday	Tuesday	Wednesday	Thursday	Friday
	9:00 -1:00 Room 4	9:00 -1:00 Room 4		9:00 -1:00 Room 4

1.   

Project the page. Students point to, then tick the days when Ming goes to class.

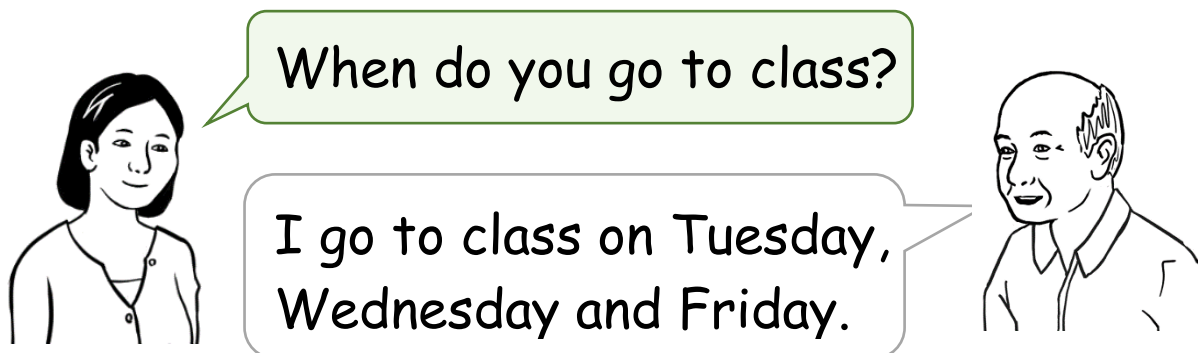

Day	✓
Monday	
Tuesday	✓
Wednesday	
Thursday	
Friday	

2.  

Tuesday	Wednesday	Friday
Tuesday	Wednesday	Friday





Project the page and ask questions about when San and Rahim go to class. e.g. *When do they go to class?*  
*When do they start class?* etc



This is Rahim and San's timetable.

Monday	Tuesday	Wednesday	Thursday	Friday
9 - 1	9 - 1	9 - 1	9 - 1	9 - 1
Room 40	Room 40	Room 40	Room 40	Room 14

1.   

Project the page. Point to, then tick the days when San goes to class.

When do you go to class San?

I go to class on Monday, Tuesday, Wednesday, Thursday and Friday.

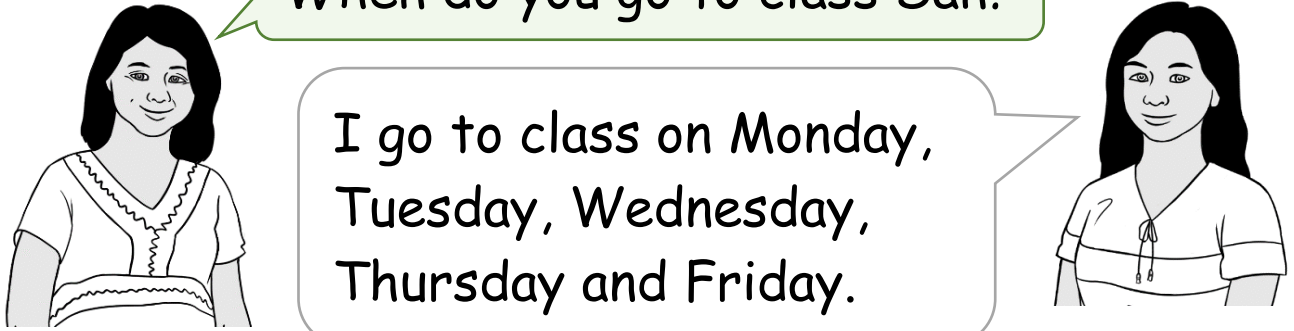

Day	✓
Monday	✓
Tuesday	
Wednesday	
Thursday	
Friday	

<b>Monday</b>	<b>Tuesday</b>	
<u>M</u> onday	__uesday	
<b>Wednesday</b>	<b>Thursday</b>	<b>Friday</b>
__ednesday	__ursday	__iday

1.  

When do you go to class?



Day	✓
Monday	
Tuesday	
Wednesday	
Thursday	
Friday	

2.  

Monday	Tuesday	Wednesday
<u>Monday</u>	____day	____nesday

Thursday	Friday	Saturday
____day	____day	____urday



M	o	n	d	a	y
M	o	n	d	a	y

T	u	e	s	d	a	y

W	e	d	n	e	s	d	a	y

T	h	u	r	s	d	a	y

F	r	i	d	a	y

S	a	t	u	r	d	a	y

S	u	n	d	a	y

# 8 When do you start class?





Project the page. Point to times on the timetable extract.

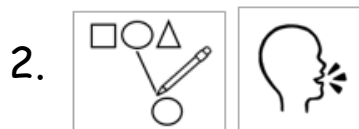

I start class at 9 o'clock.  
I finish at 1 o'clock.

<b>Monday</b>
<b>9:00 - 1:00</b>
<b>Room 40</b>

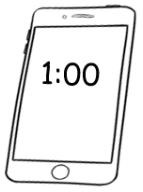

<b>9 o'clock</b>	
<b>1 o'clock</b>	

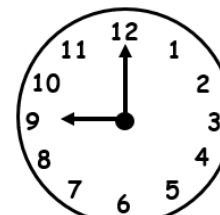
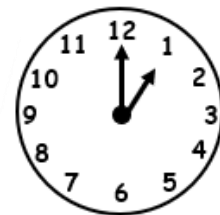



1.

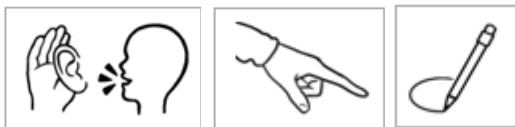

Project the page. Point to, then circle the times on the timetable extract.

I start class at 9 o'clock.  
I finish at 1 o'clock.

Monday
9:00 - 1:00
Room 16



2.



When do you start class?

When do you finish?

I start class at \_\_\_\_ o'clock.

I finish at \_\_\_\_ o'clock.

# 9 I am sorry. I am late.

Project the following 4 pages.

Class starts at 9 o'clock.

1.

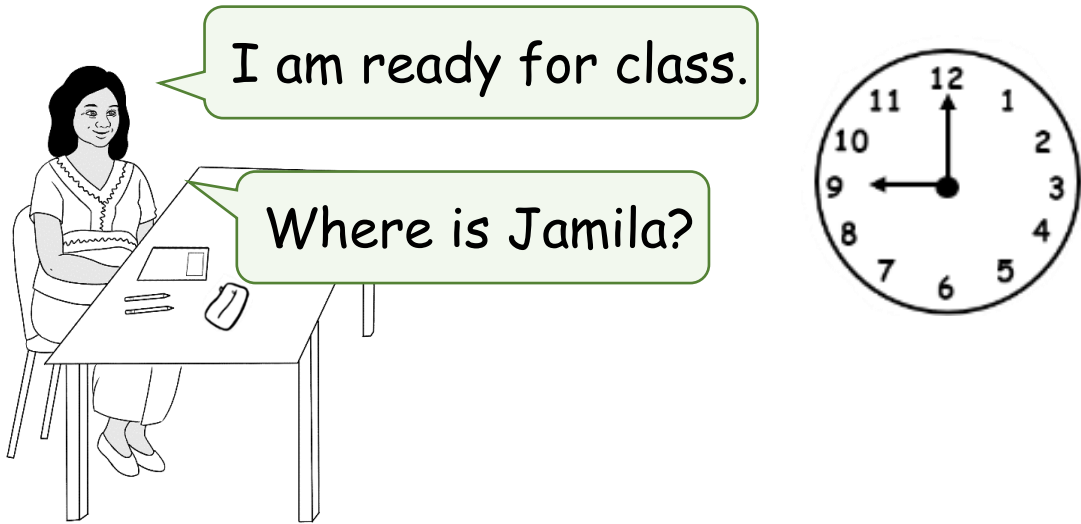

2.

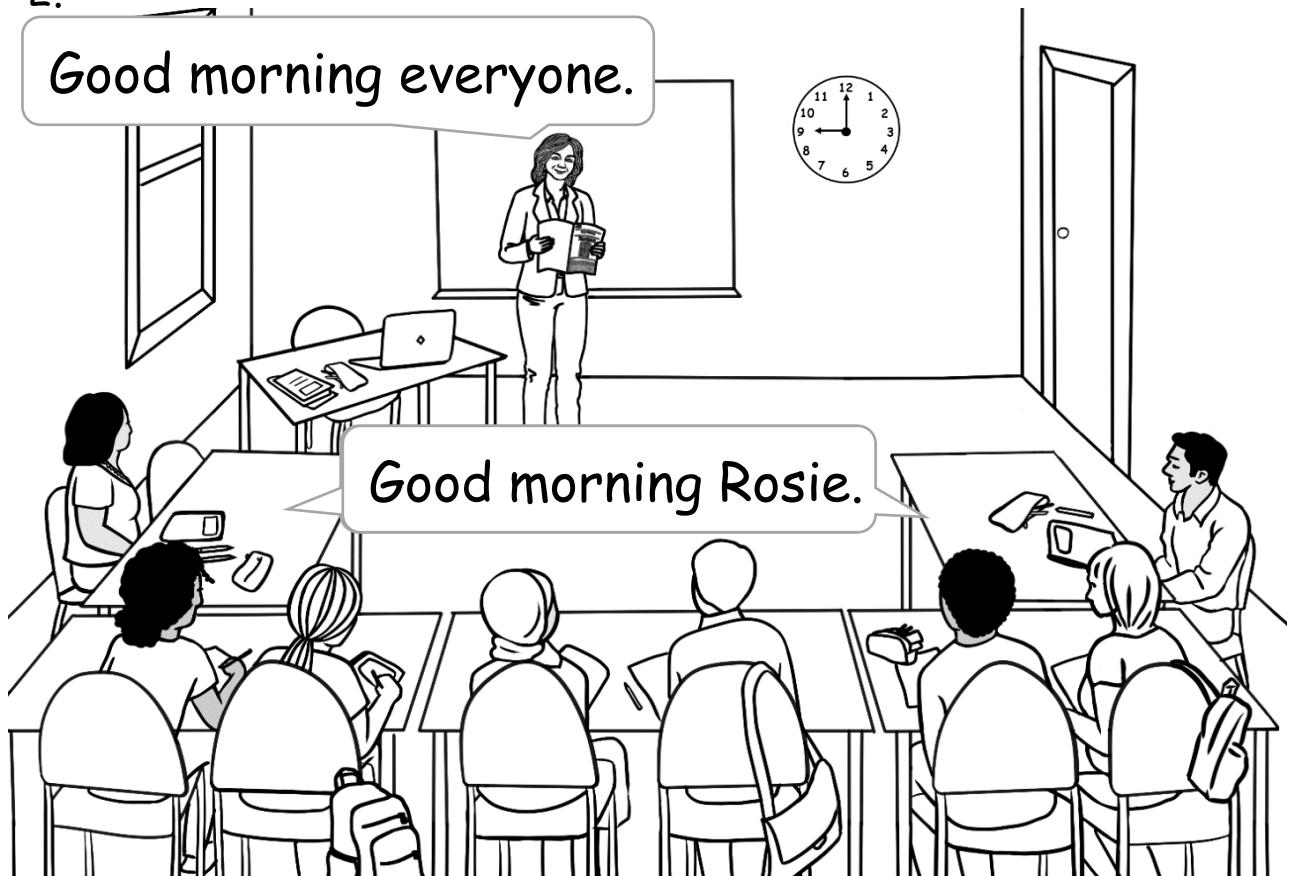



3.



I am late.

It is 10 o'clock.



4.

Good morning Jamila.

Good morning Rosie.  
I am sorry. I am late.

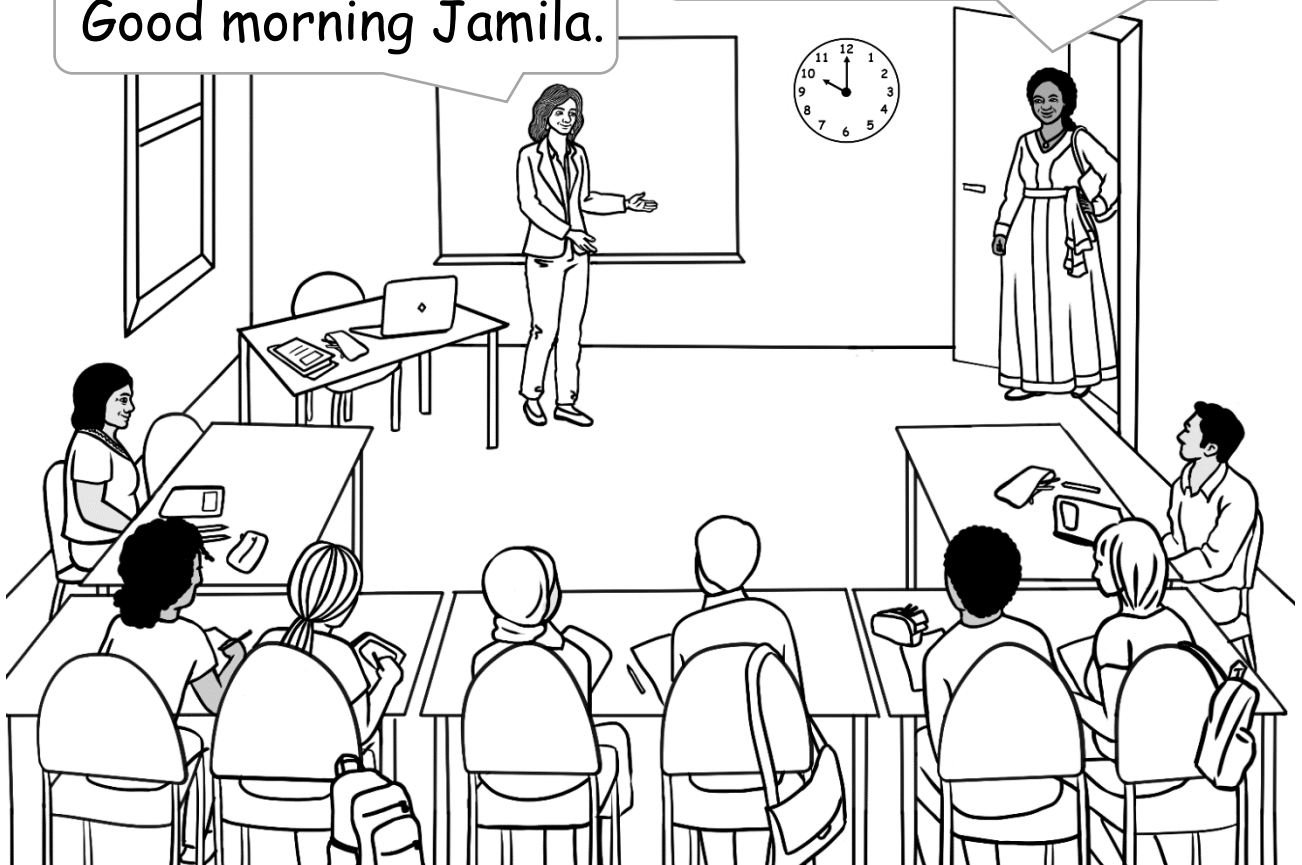



Jamila doesn't know the page because she was late.

5.



Page 13.

What page Rosie?



6.



Chant and clap together.

Come on time.  
Come on time.  
Our class  
starts at 9.

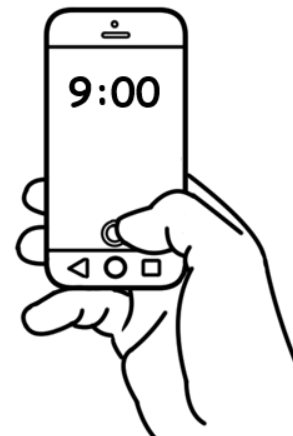



Next day Jamila arrives **before 9**. This page aims to show the importance of being early, for both learning and friendship. The conversation in exercise 8 could be extended to talk about family, the weather, weekend etc

7.

The next day

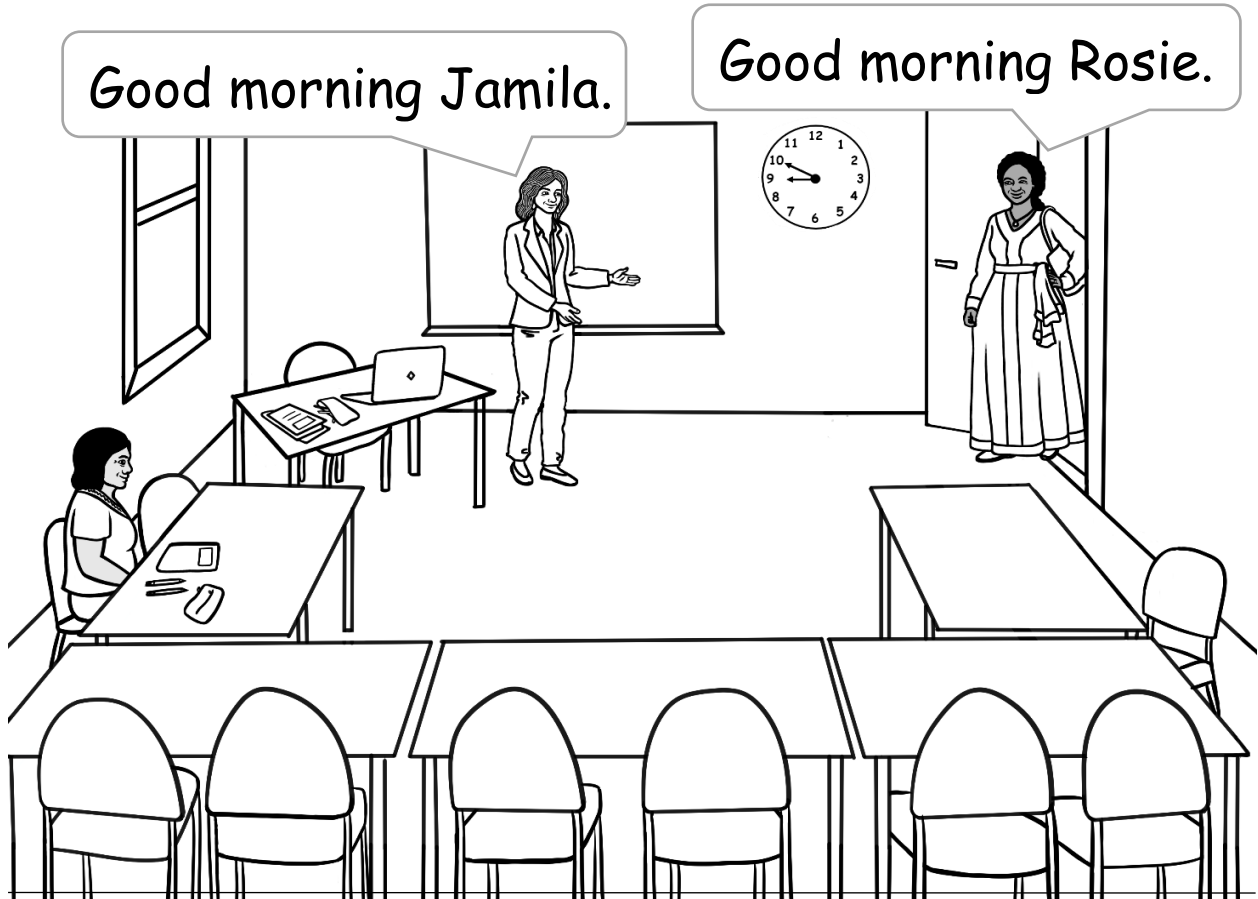

Good morning Jamila.

Good morning Rosie.

8.

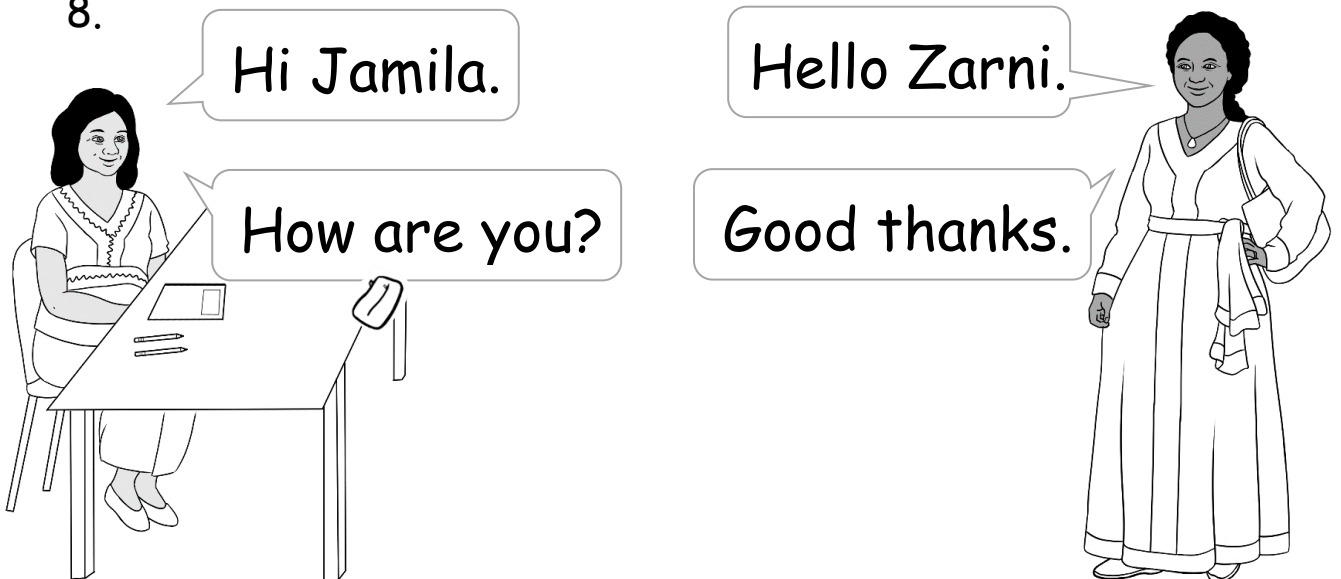

Hi Jamila.

Hello Zarni.

How are you?

Good thanks.

# 10 Do you have a pencil?



Direct students to colour some of the objects.  
e.g. Colour the pen red.

1.



pencil

2.

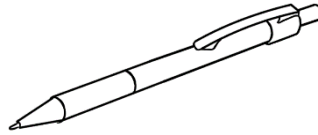

pen

3.

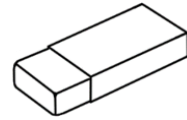

rubber

4.

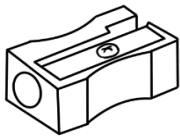

sharpener

5.

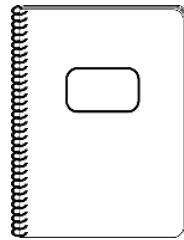

notebook

6.

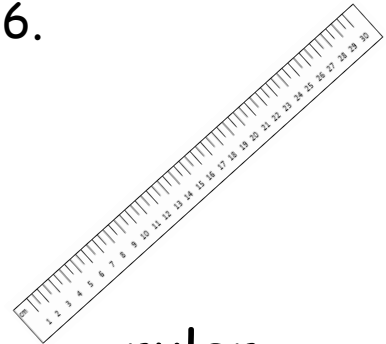

ruler

7.

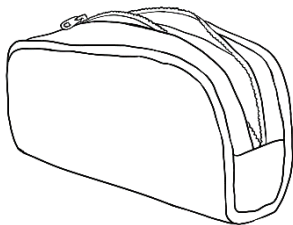

pencil case

8.



water bottle



9.

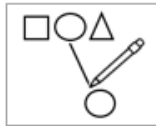

glasses

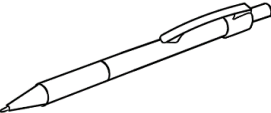
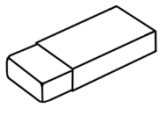
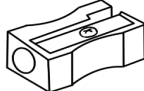
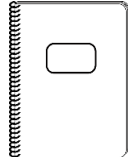
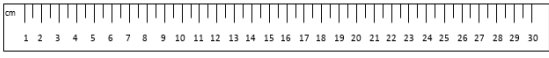
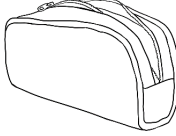

Listen, repeat, match and then ask questions.  
e.g. What's number 3?

1. pencil	
2. pen	
3. rubber	
4. sharpener	
5. notebook	
6. ruler	
7. pencil case	
8. water bottle	
9. glasses	

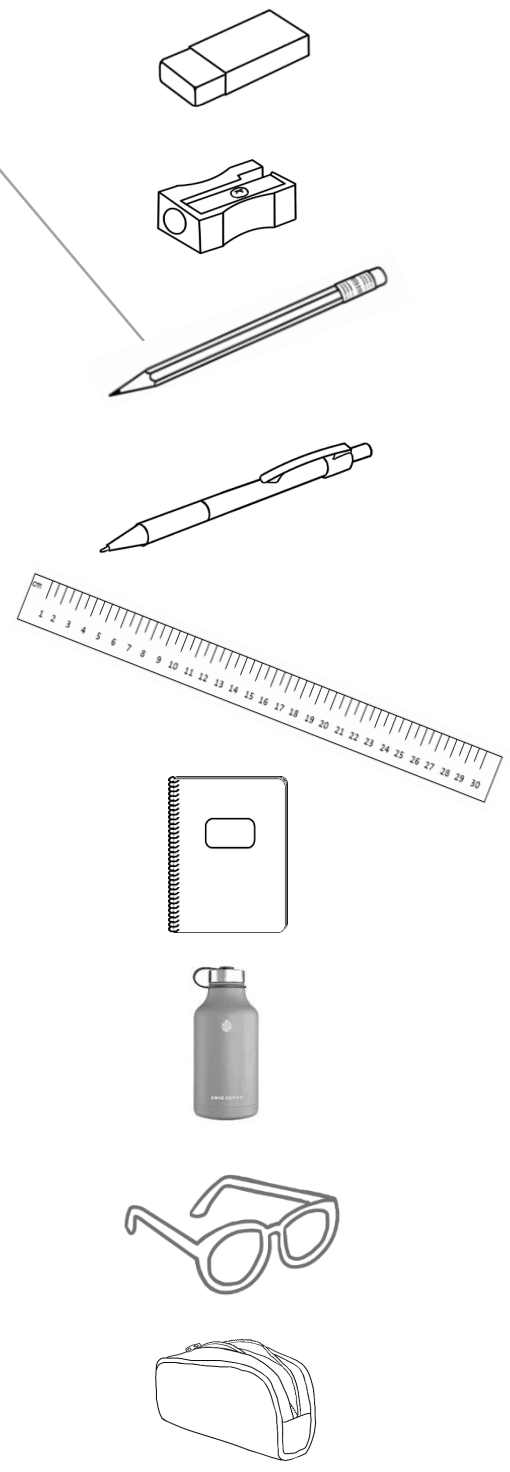



1.



Do you have a pencil?

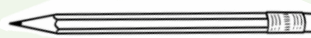

Yes.



2.



Do you have a rubber?



No.



3

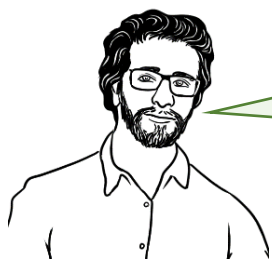

What do you have?

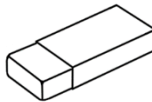
		✓
I have a pencil.		
I have a rubber.		





What do you have?



1. I have a pen.

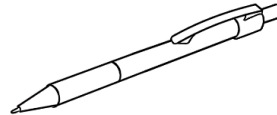

2. I have a sharpener.

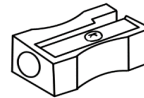

3. I have a notebook.

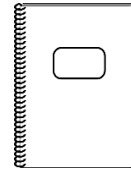

4. I have a ruler.

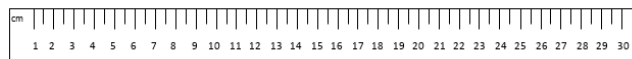

5. I have a pencil case

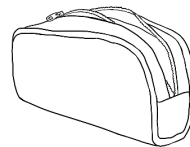



6. I have a water bottle.



7. I have glasses.



1.  

San's pencil case

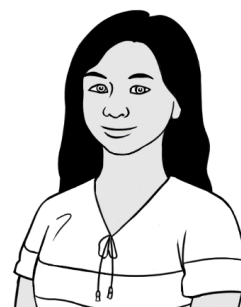

1. pencil 

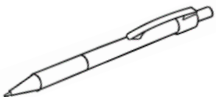
2. pen 

3. rubber 

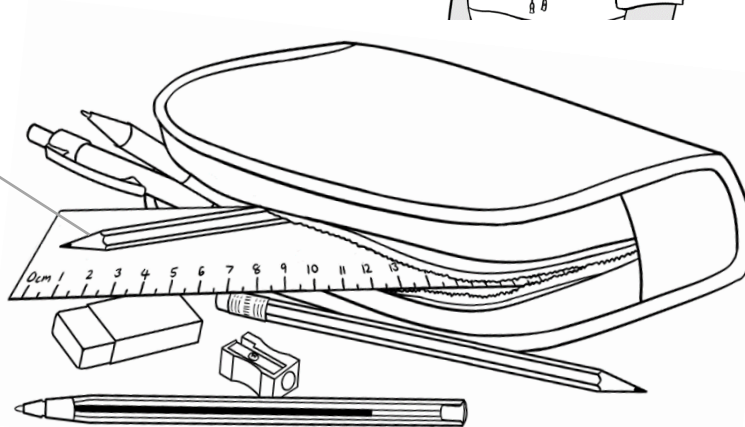



4. ruler 

5. sharpener 

2.  

Emphasise the initial consonants - p and r.  
Copy the first letter.

 pencil  
\_encil

pen   
\_en

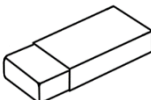
 rubber  
\_ubber

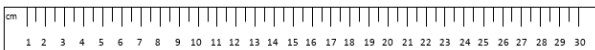
ruler  
\_uler 





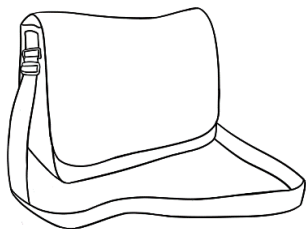



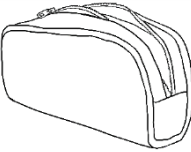
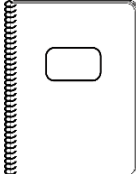

Listening activity. Read what Rahim has in his bag; students tick the items. The items are **not** ticked in the student book. NB. Rahim wears glasses when studying.

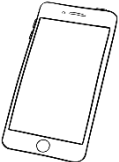

Rahim's bag



1. a pencil case		
2. a notebook		
3. a water bottle		
4. a phone		
5. glasses		
6. an apple		
7. an umbrella		







Listening activity. Read what San has in her bag; students tick the items. The items are **not** ticked in the student book.

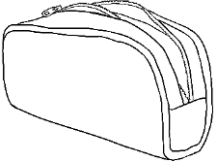

San's bag

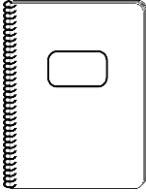
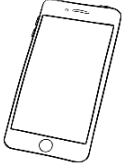



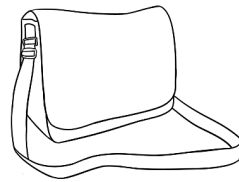



1. a pencil case		
2. a notebook		
3. a water bottle		
4. a phone		
5. glasses		
6. an apple		
7. an umbrella		

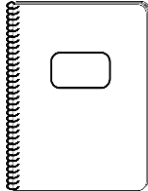

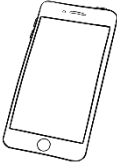
What is in **your** bag?

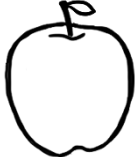

1. a pencil case		
2. a notebook		
3. a water bottle		
4. a phone		
5. glasses		
6. an apple		
7. an umbrella		

# 11 I want to learn English.



Project the pages in this section. Help students understand that to learn English and achieve their goals, they need to study **actively** in and after class. See the Teacher Resources for ways to practise the strategies in this section.



I want to be a painter.

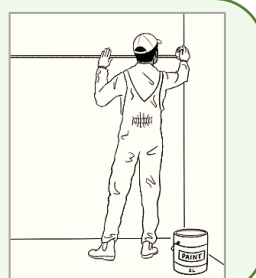

In class

1. I come to class before 9 o'clock.

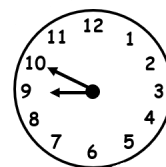

2. I have

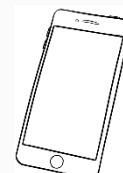

3. I ask questions.

Say it again please?

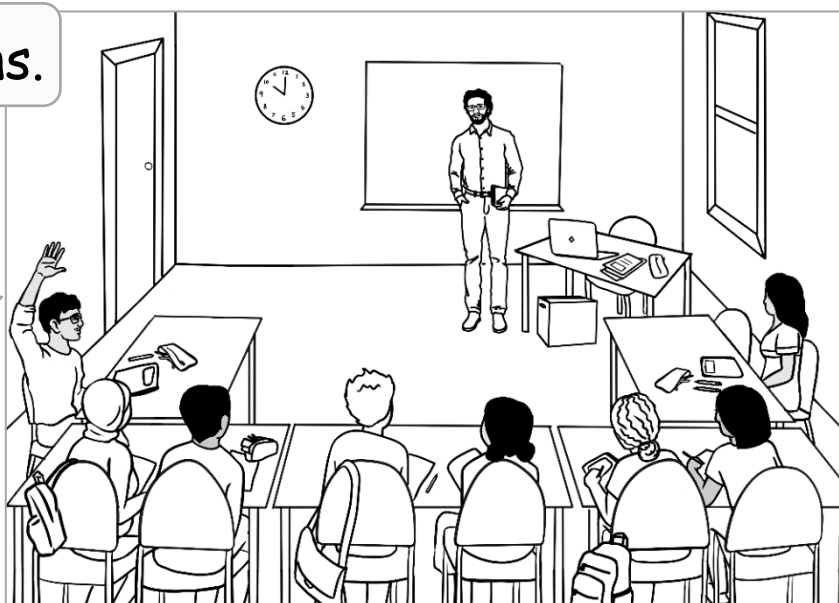



After class

4. I do my homework.



5. I copy words into my notebook.

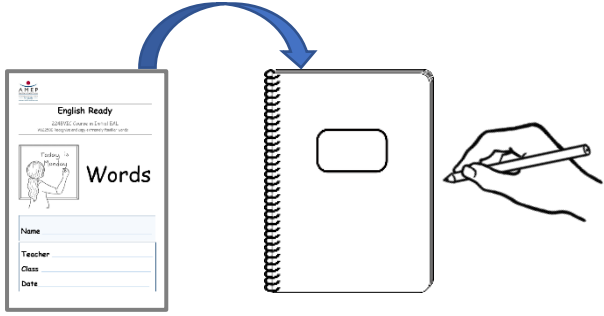

6. I talk to my friend in English.

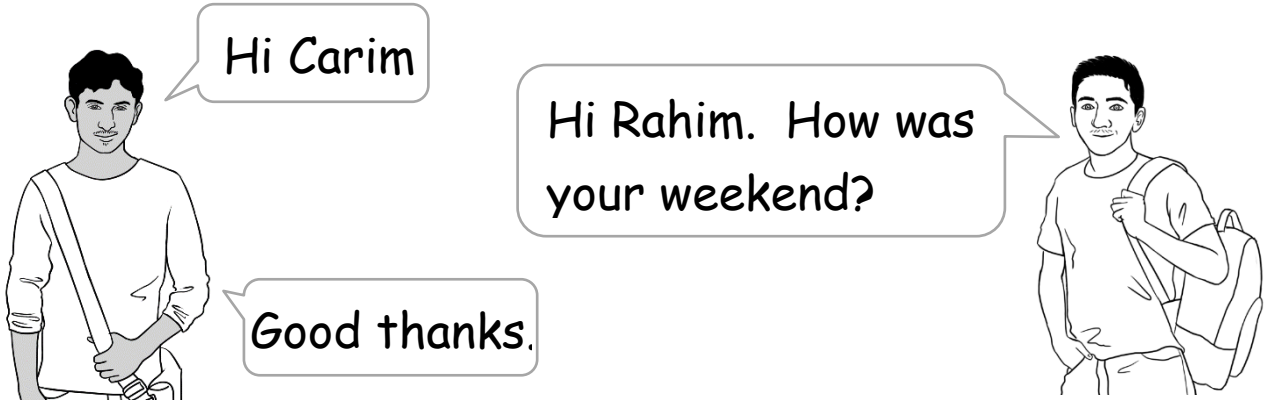



I want to work with children.

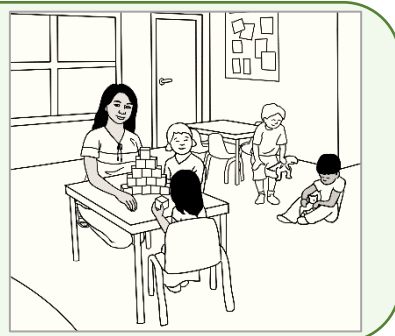

In class

1. I ask for help.

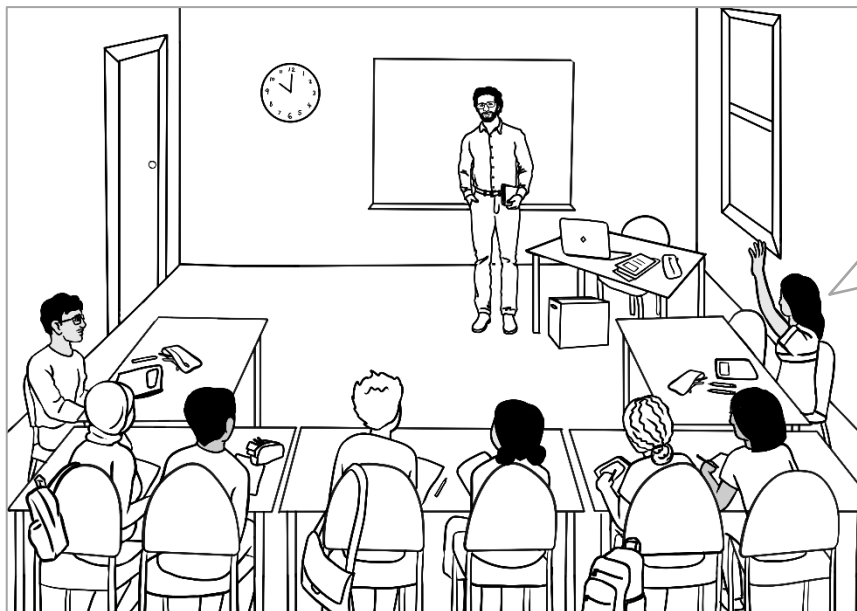

Can you help me please?

2. I record the teacher.



I have a pencil.







After class

3. I listen to the teacher.  
I repeat the words.

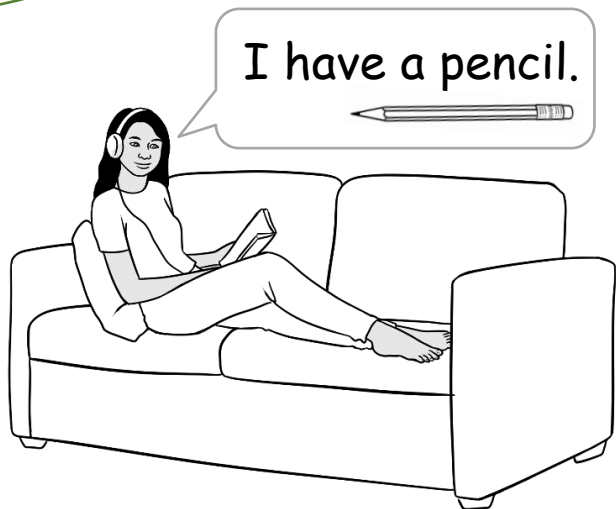

4. I talk to my neighbours.



5. I learn new words.

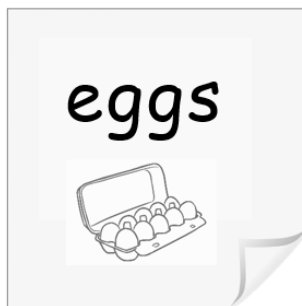



I want to be a cook.



In class

1.

I say the sounds. I copy the sounds.



apple a  
bag b.

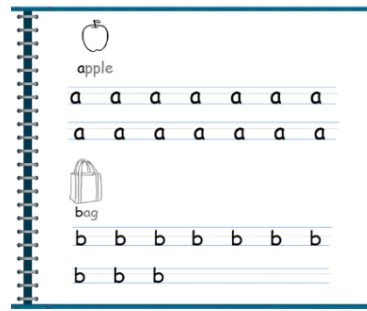

2.

I match the words. I say the words.

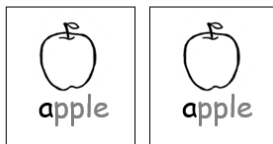

apple



3.

I talk to my friend in English.



Hi Zarni.

How is San?

Hi Jamila.

She is sick today.





## After class

4. I learn with a volunteer. I learn the sounds.



5. I use a laptop in the library.





#1 Ming says, *I go to class.* This stresses regular attendance.



I want to talk to my grandchildren.



In class

1. I go to class.

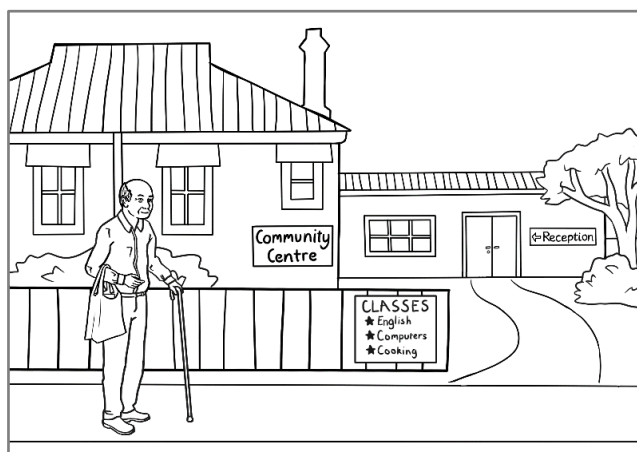

2. I listen and repeat.



Monday

Monday



3. I ask for help.

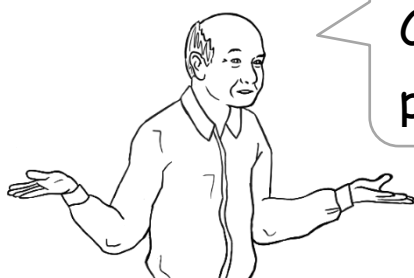

Can you help me please Wendy?





After class

4. I go to the library.



I read  and listen. 

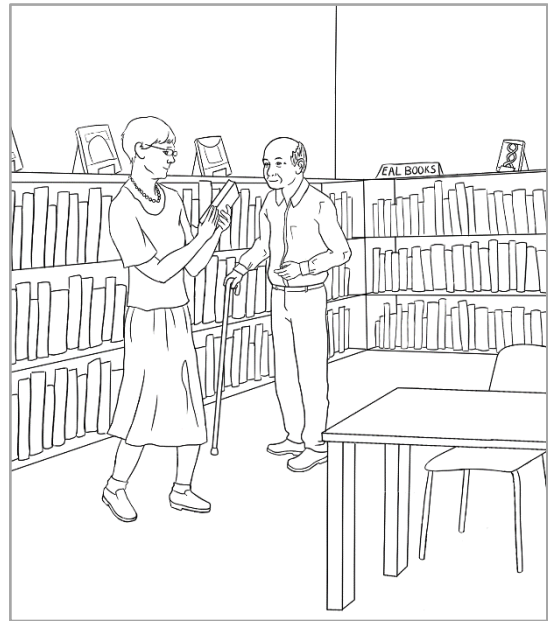

5. I do my homework.

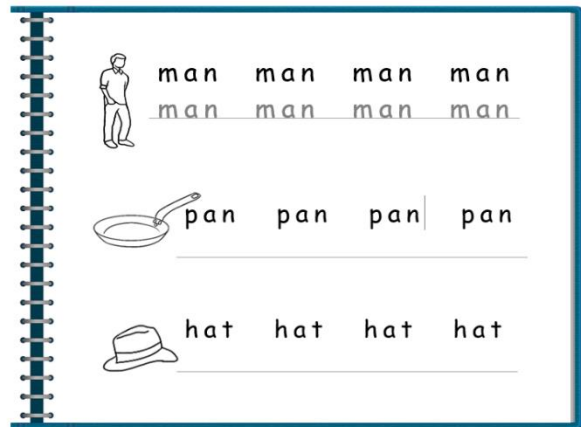

6. I talk to my grandchildren.



What do you do in class?

I use the computer.





In class

What do you do?



1

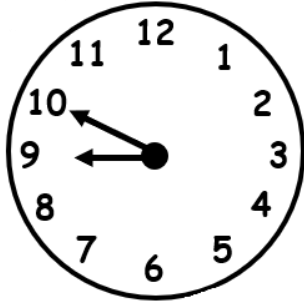

2

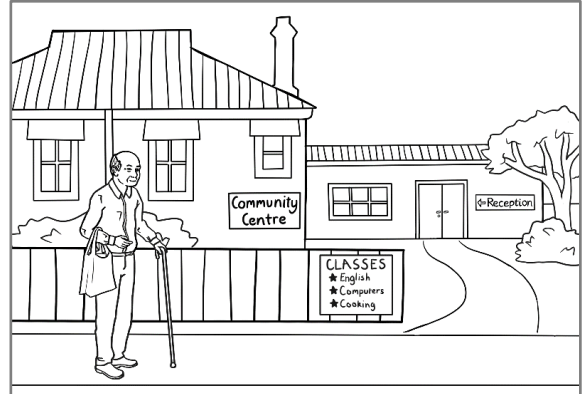

3

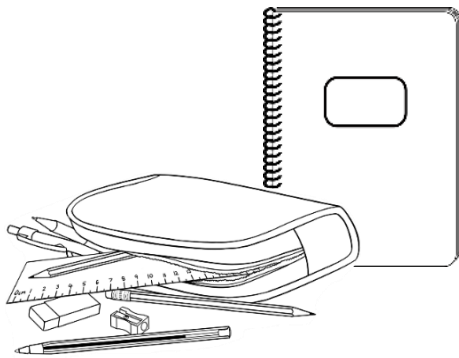

4

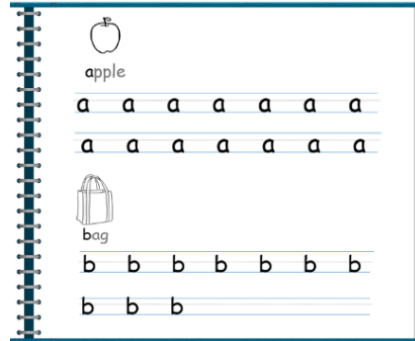

5



6

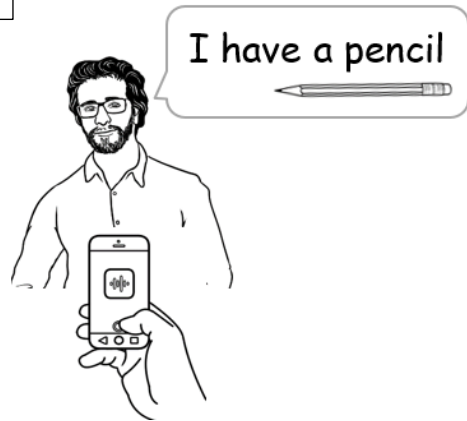



# After class



What do you do?

1

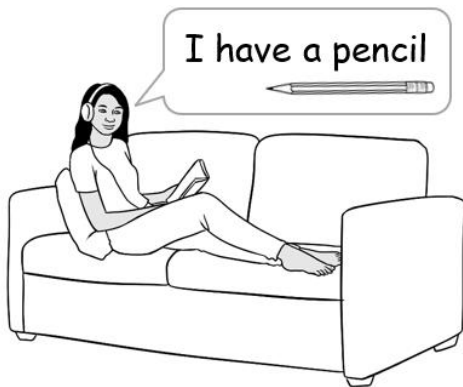

2



3



4



5

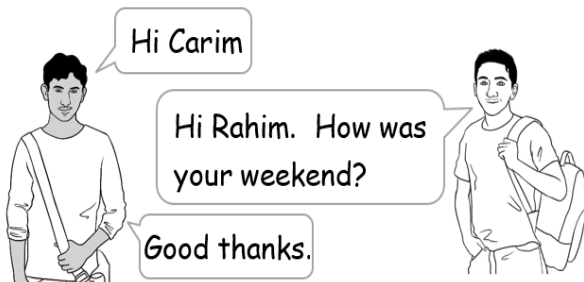

6



# 12 Follow instructions.

This section focuses on the instruction icons.

Read and point to all the letters. Instruct students to circle different letters. If coloured pencils are available, instruct students to circle in specific colours.

1.



Circle b.



a	b	c	d	e	f	g
h	i	j	k	l	m	

n	o	p	q	r	s	t
u	v	w	x	y	z	

2.



Instruct students to tick different letter names.

Tick d.



a	b	c	d	e	f	g	h	i	j	k	l	m
			✓									



3.



Instruct students to tick different letter names.

Tick r.



n	o	p	q	r	s	t	u	v	w	x	y	z
				✓								

4.



Read and point to all the letters. Instruct students to colour the boxes under specified letters.

Colour F





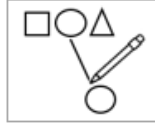

A	B	C	D	E	F	G	H	I	J	K	L	M

N	O	P	Q	R	S	T	U	V	W	X	Y	Z

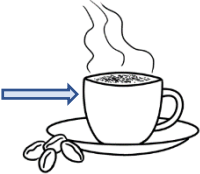
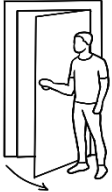
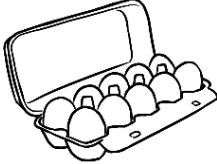

Listen, point and repeat the words and first sounds. Match the first letters. Revise later by instructing students to circle/tick a sound, or colour an object.

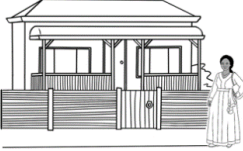
1. <b>apple</b>		<b>a</b>
2. <b>bag</b>		<b>b</b>
3. <b>cup</b>		<b>c</b>
4. <b>door</b>		<b>d</b>
5. <b>eggs</b>		<b>e</b>
6. <b>family</b>		<b>f</b>
7. <b>glasses</b>		<b>g</b>
8. <b>home</b>		<b>h</b>

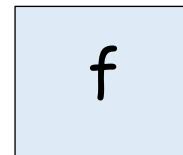
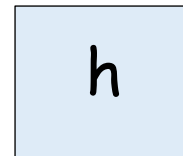
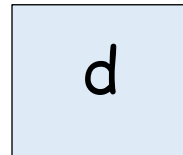
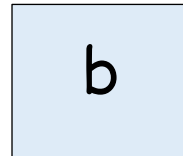
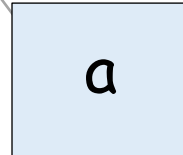
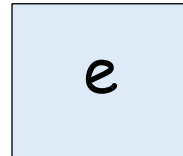
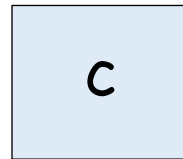



Listen, point and say the words and initial sounds. Work from left to right. Revise later by instructing students to circle/tick a sound, or colour an object.



9.



**ink**  
\_ink

10.



**jacket**  
\_\_acket

11.



**kids**  
\_\_ids

12.



**lemon**  
\_\_emon

13.



**man**  
\_\_an

14.



**no**  
\_\_o

15.

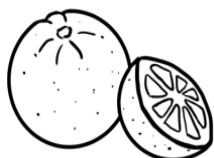

**orange**  
\_\_range

16.



**pencil**  
\_\_encil

17.



**queen**  
\_\_ueen

18.

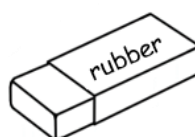







**rubber**  
\_\_ubber

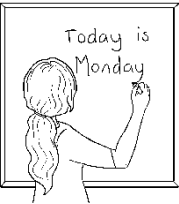

Listen and say the words and sounds.

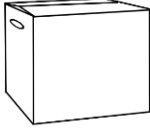
Colour the sounds. Revision - Tick or circle the sounds.

19.	<b>student</b>		<b>S</b>
20.	<b>teacher</b>		<b>t</b>
21.	<b>umbrella</b>		<b>u</b>
22.	<b>van</b>		<b>v</b>
23.	<b>woman</b>		<b>w</b>
24.	<b>box</b>		<b>x</b>
25.	<b>yes</b>		<b>y</b>
26.	<b>zero</b>		<b>z</b>

1.



Listen and repeat the numbers.  
Count and clap the syllables.  
Revision - colour or tick numbers.

2.



Instruct students to circle different numbers.



1	2	3	4	5
6	7	8	9	10
11	12	13	14	15
16	17	18	19	20
21	22	23	24	25
26	27	28	29	30
31	32	33	34	35
36	37	38	39	40
41	42	43	44	45
46	47	48	49	50

# 13 I am sick.

1.



2.



I text my teacher.



3.



Hi Peter

Hi \_eter

I am sick.

\_ \_m \_ick.

San

\_an

4.



I am sick.

\_ \_ \_ .

I am sick.

\_ \_ \_ .



Text the teacher.

1.



Students listen and copy the teacher's phone number below and onto their phone.

0	1	2	3	4	5	6	7	8	9
---	---	---	---	---	---	---	---	---	---

My teacher's phone number is

--	--	--	--	--	--	--	--	--	--

2.



Write your name on a slip of paper so students can copy it and also their own name into the text template below. Students then copy the model text on their phone and send the message to the teacher.

Hi \_\_\_\_\_

I am sick.

\_\_\_\_\_





This chant could be said at the end of every class.

Bye.

See you soon.

Bye.

See you later.

Bye.

See you tomorrow.

